

ISL95820EVAL1Z Evaluation Board User Guide

Hardware Description

The ISL95820EVAL1Z evaluation board demonstrates the performance of the ISL95820 4-phase voltage regulator for Intel VR12.5 and VR12.6 CPUs. The ISL95820 features Intersil's Robust Ripple Regulator R3 Technology™. An on-board dynamic-load generator is included for evaluating the transient-load response. It applies a 300µs pulse of approximately 0.05Ω/0.1Ω load across V_{CORE} and PGND.

Contents of this document include:

- Design criteria
- Recommended test equipment
- Interface connections
- Switch descriptions
- Photographs of the evaluation board and PMBus interface module.
- Jumper and connector descriptions
- Test point descriptions
- Evaluation board documentation
 - Bill of materials
 - Schematic
 - Silk-screen plots
 - Board layer plots

TABLE 1. DC/DC DESIGN CRITERIA

PARAMETER	VALUE	UNITS
V _{IN}	12	VDC
V _O	0 to 2.30	VDC
Full-load	100	ADC
PWM Frequency	300	kHz

Recommended Equipment

- (Qty. 1) Adjustable 20V, 15A power supply (for V_{IN})
- (Qty. 1) Fixed 5V, 100mA power supply (for VDD)
- (Qty. 1) Fixed 12V, 100mA power supply (for the dynamic-load generator)
- (Qty. 1) Adjustable constant current electronic load
- (Qty. 1) Digital voltmeter
- (Qty. 1) Four-channel oscilloscope

Interface Connections

- V_{IN}: Input voltage to the power stage
 - J5: V_{IN} positive power input
 - TP18: V_{IN} positive voltage sense
 - J6: V_{IN} return power input
 - TP32: V_{IN} return voltage sense
- CPU V_{CORE}: CORE regulated output voltage
 - J11 and J12: V_{CORE} positive power output
 - J13 and J14: V_{CORE} return power output
- +5V: +5V input voltage
 - TP29: +5V positive input
 - TP16: +5V sense
 - TP30: +5V return input
- +12V: Input voltage for the dynamic-load generator
 - TP3: 12V positive input
 - TP2: 12V return input

Switch Descriptions

- S3: Enable
 - OFF: Short the VR_ON pin to GND (disable PWM)
 - ON: Allow the VR_ON pin to pull-up to +5V (enable PWM)
- S2: Dynamic load for CPU
 - OFF: On-board dynamic load disabled
 - ON: On-board dynamic load enabled

Evaluation Board Photograph

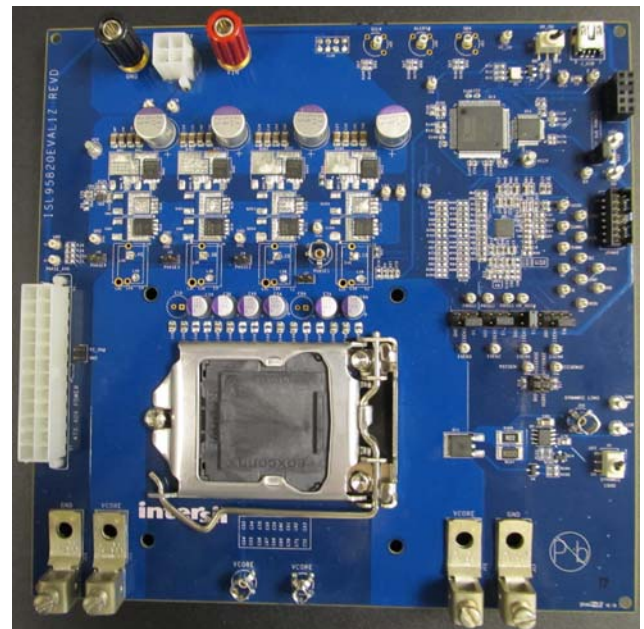

Application Note 1902

The ISL95820 evaluation board features an Intel processor socket (reference designator U2), intended for the installation of an Intel VRTT (Voltage Regulator Test Tool) Interposer. This device is required for VR platform validation, to establish compliance with various Intel platform performance specifications.

Test Set-Up

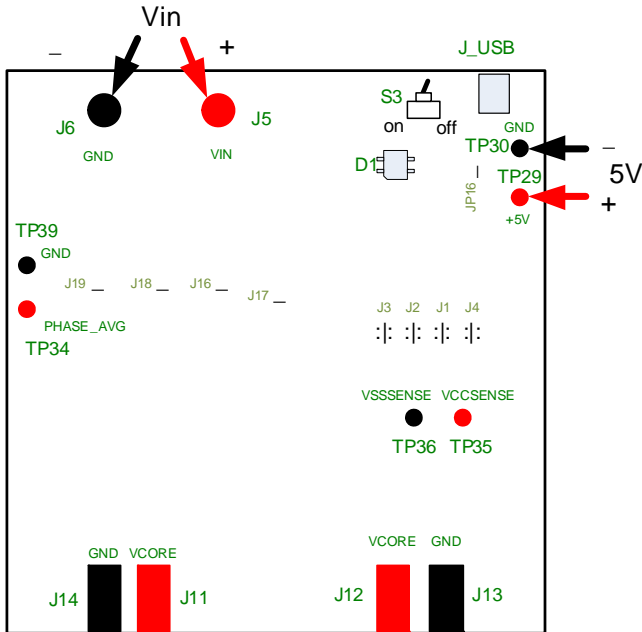

FIGURE 1. TEST SET-UP

- Apply V_{IN} (recommend +12V) to J5/J6 and apply +5V to TP29/TP30. LED D1 should be red when S3 is off. Then flip on S3 to start up controller. The following facts need to be established for a good board:
 - LED D1 turns green.
 - Voltage meter measurement on TP35/TP36 shows ~1.70V.

SVID Test Procedure

- Connect the evaluation board and PC using USB-mini USB cable inserted into the J_USB receptacle.
- Power on the evaluation board as previous test set-up procedure.
- Start up Intersil SVID control software. Select the SVID/PMBus Control tab. The USB interface status will turn green for correct connection.
- Using the SVID section of the interface, with SVID address 0h, set VID to 1.800V, then click “SEND”. One “ACK” message will be received for correct communications.
- Voltage meter measurement on TP35/TP36 for ~1.80V will indicate a good on-board SVID emulator.

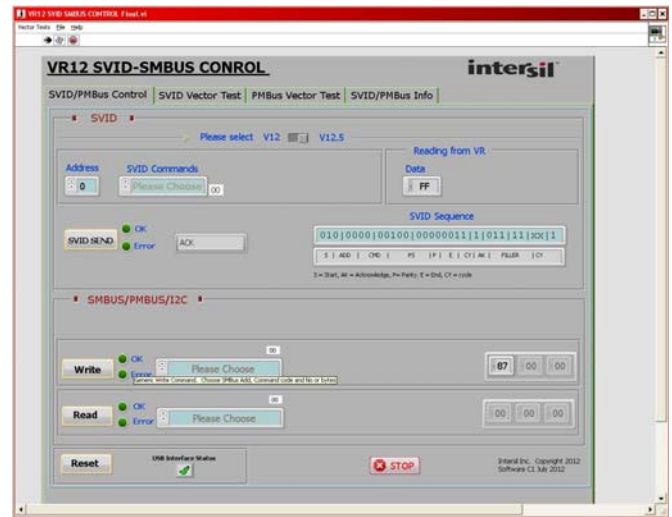

FIGURE 2. SVID/SMBus EMULATOR SOFTWARE

Operation of the PMBus interface requires an Intersil-supplied interface module, as shown in Figure 3. See the ISL95820 datasheet for information about the PMBus interface.

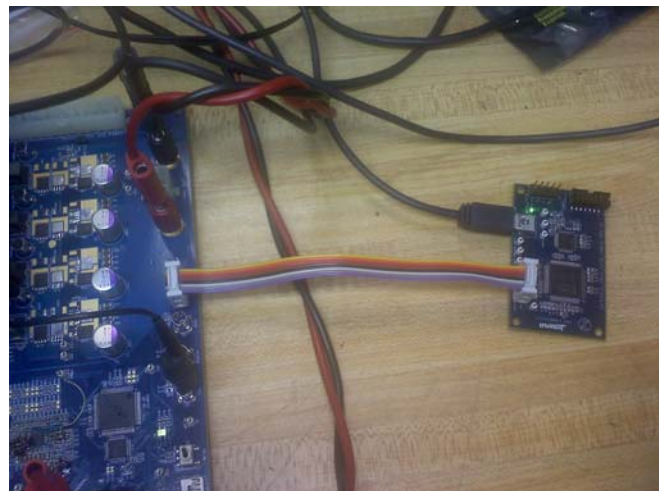

FIGURE 3. PMBUS INTERFACE MODULE CONNECTION TO THE EVALUATION BOARD

Jumper and Connector Descriptions

In the following sections, jumpers, connectors, and test points are ordered by reference designator. Items with related functions may be grouped by color.

- **JUSB:** USB cable connection, for running the Intersil SVID control software
- **JHDR2:** Required for programming the USB-to-SVID interface
- **JTAG1:** Required for programming the USB-to-SVID interface
- **JCON:** Ribbon cable connection to the PMBus interface module.
- **J1:** Set ISEN1 connection. Connect ISEN1 to driver (the middle jumper) for 1-, 2-, 3-, or 4-phase operation.
- **J2:** Set ISEN2 connection. Connect ISEN2 to driver (the middle jumper) for 2-, 3-, or 4-phase operation. If ISEN2 is connected to +5V, phase-2 (and phase-3 and phase-4) will be disabled.
- **J3:** Set ISEN3 connection. Connect ISEN3 to driver (the middle jumper) for 3-, or 4-phase operation. If ISEN3 is connected to +5V, phase-3 (and phase-4) will be disabled.
- **J4:** Set ISEN4 connection. Connect ISEN4 to driver (the middle jumper) for 4-phase operation. If ISEN4 is connected to +5V, phase-4 will be disabled.
- **J5:** VIN banana receptacle (red)
- **J6:** VIN return (ground) banana receptacle (black)
- **J7:** ATX 12V connector
- **J8:** ATX AUX POWER connector
- **J11:** VCORE screw lug, for external load connection
- **J12:** VCORE screw lug, for external load connection
- **J13:** Ground screw lug, for external load connection
- **J14:** Ground screw lug, for external load connection
- **JP16:** If the jumper is installed, the +5V rail supplies the +3.3V, +2.5V, 1.2V rails to the auxiliary circuit on the board. When measuring board efficiency, remove the jumper and apply +3.3V to TP37.
- **J16:** Install the jumper to include Phase 2 in the PHASE_AVG resistive sum test point. With the jumper removed, the pin closest to L2 can be used as a Phase 2 test point.
- **J17:** Install the jumper to include Phase 1 in the PHASE_AVG resistive sum test point. With the jumper removed, the pin closest to L1 can be used as a Phase 1 test point.
- **J18:** Install the jumper to include Phase 3 in the PHASE_AVG resistive sum test point. With the jumper removed, the pin closest to L3 can be used as a Phase 3 test point.
- **J19:** Install the jumper to include Phase 4 in the PHASE_AVG resistive sum test point. With the jumper removed, the pin closest to L4 can be used as a Phase 4 test point.
- **J23:** ATX AUX POWER PS_ON# grounding jumper

Test Point Descriptions

TEST POINT	DESCRIPTION
TP1	VR_ON, active high
TP2	VIN return (ground) for 12V dynamic load supply
TP3	VIN for 12V dynamic load supply
TP4	COMP pin. This is the voltage feedback error amplifier output, which is the input to the R3™ Modulator.
TP5	Ground
TP6	FB pin
TP7	VR temperature sense NTC pin
TP8	VR_HOT#, open-drain temperature fault output pin, pulled up to VTT
TP9	IMON pin, DC output current monitor and programming
TP10	ISEN1 pin, phase 1 current balance input
TP11	ISEN2 pin, phase 2 current balance input
TP12	ISEN3 pin, phase 3 current balance input
TP13	PGOOD pin, open-drain voltage good status output, pulled up to +3.3V
TP14	VSEN, kelvin sense of the output voltage at the load (the U2 Interposer), also response pin for loop transfer function testing.
TP15	VSEN1, kelvin sense of the output voltage at the load (the U2 Interposer), also excitation pin for loop transfer function testing.
TP16	+5V, VDD (and optional 5V driver) supply sense pin
TP17	3.3V return (ground) sense
TP18	VIN (12VDC) supply test point
TP19	ISUMP pin, part of the output current sense mechanism
TP20	ISUMN, part of the output current sense mechanism
TP21	ISUMN1, on the ISUMN pin, part of the output current sense mechanism
TP22	ISEN4 pin, phase 4 current balance input
TP23	UG1, phase 1 upper FET gate signal
TP24	PROG1 pin
TP25	PROG2 pin
TP26	PROG3 pin
TP27	VDR, phase 4 external driver supply post and test point
TP28	FB2 pin

Application Note 1902

Test Point Descriptions (Continued)

TEST POINT	DESCRIPTION
TP29	+5V supply input connection post. Clip +5V VDD (and optionally +5V driver) supply to this post.
TP30	+5V supply return (ground) input connection post. Clip the ground return connection for VDD (and optionally +5V driver) supply to this post.
TP31	VCCP pin, phase 1-3 integrated driver supply post and test point
TP32	PGND sense, VIN return (ground) sense point
TP33	LG1, phase 1 lower FET gate signal
TP34	PHASE_AVG, the resistive summation of the (jumper installed) phase signals
TP35	VCCSENSE, kelvin sense of the output voltage at the load.
TP36	VSSSENSE, kelvin sense of the output voltage return (ground) at the load.
TP37	3.3V rail, output of U9 LDO
TP38	VTT, 1.05V rail, output of U8 LDO
TP39	Ground
TP40	Ground
TP41	Ground
TP42	Ground
TP44	Ground
TPW4	PWM4
J9	VCORE oscilloscope grounded-barrel probe connection, for small barrel probes
J10	VCORE oscilloscope grounded-barrel probe connection, for large barrel probes
J15	Dynamic load current sense, oscilloscope grounded-barrel probe connection, for large barrel probes
J17	PHASE1 test point (pin nearest L1). This is also part of the PHASE_AVG test point jumper network.
J16	PHASE2 test point (pin nearest L2). This is also part of the PHASE_AVG test point jumper network.
J18	PHASE3 test point (pin nearest L3). This is also part of the PHASE_AVG test point jumper network.
J19	PHASE4 test point (pin nearest L4). This is also part of the PHASE_AVG test point jumper network.

Test Point Descriptions (Continued)

TEST POINT	DESCRIPTION
J20	ALERT#, open drain SVID bus signal, oscilloscope grounded-barrel probe connection, for large barrel probes
J21	SDA, SVID bus data signal, oscilloscope grounded-barrel probe connection, for large barrel probes
J22	SCK, SVID bus clock signal, oscilloscope grounded-barrel probe connection, for large barrel probes
J24	4-pin differential-probe VCORE test point. These four pins are arranged to permit differential voltage sensing (with pin-insertion socket diff-probes on 0.1" centers) of (a) VCCSENSE-VSSSENSE; (b) VCORE-GND; (c) VSSSENSE-GND; and (d) VCCSENSE-VCORE. Pins are labeled in the silkscreen.
J25	PHASE1 oscilloscope grounded-barrel probe connection, for large barrel probes

Application Note 1902

Bill of Materials

QTY	REFERENCE DESIGNATOR	DESCRIPTION	MANUFACTURER	MANUFACTURER PART
0	a) C15, C32, C37, C41, C42, C43, C46, C47, C50	CAP, SMD, 0805, DNP-PLACE HOLDER, ROHS		
26	a) C22, C31, C39, C40, C44, C45, C48, C49	CAP, SMD, 0805, 22µF, 6.3V, 20%, X5R, ROHS	TDK	C2012X5R0J226M
17	a) C27, C28, C29, C33, C34, C35, C80, C9N	CAP, SMD, 1206, 10µF, 25V, 10%, X7R, ROHS	VENKEL	C1206X7R250-106KNE
24	a) C74, C77, C78, C126, C128, C133, C135, C136,	CAP, SMD, 0402, 0.1µF, 16V, 10%, X7R, ROHS	VENKEL	C0402X7R160-104KNE
0	a) Q1D1-Q1D4, Q2D1-Q2D4, Q3D1-Q3D4,	DO NOT POPULATE OR PURCHASE		
8	a) R114, R115, R140, R141, R185,	RES, SMD, 0603, 10k, 1/10W, 1%, TF, ROHS	KOA	RK73H1JT1002F
20	a) R22, R26, R29, R40, R138, R145, R148, R149,	RES, SMD, 0603, 0Ω, 1/10W, TF, ROHS	VENKEL	CR0603-10W-000T
9	a) R32, R33, R34, R36, R121, R135, R136,	RES, SMD, 0603, 1k, 1/10W, 1%, TF, ROHS	PANASONIC	ERJ-3EKF1001V
0	a) R4, R6, R9, R20, R27, R28, R78, R81, R83, R84,	RES, SMD, 0603, DNP-PLACE HOLDER, ROHS		
1	AFFIX TO BACK OF PCB	LABEL-DATE CODE_BOM REV#_SERIAL# LABEL ON ZIL & QUEL	INTERSIL	LABEL-DATE CODE
0	b) C10N, CN1-CN8	CAP, SMD, 1206, 10µF, 25V, 10%, X7R, ROHS	VENKEL	C1206X7R250-106KNE
0	b) C137, C138, C140, C141, C142, C143, C144,	CAP, SMD, 0402, 0.1µF, 16V, 10%, X7R, ROHS	VENKEL	C0402X7R160-104KNE
0	b) C53-C56, C59-C72	CAP, SMD, 0805, 22µF, 6.3V, 20%, X5R, ROHS	TDK	C2012X5R0J226M
0	b) C75, C76, C83, C85, C86, C88-C99	CAP, SMD, 0805, DNP-PLACE HOLDER, ROHS		
0	b) Q4D1-Q4D4 (SUD50N03-06AP-E3-T).	DO NOT POPULATE OR PURCHASE		
0	b) R142, R146, R147, R150, R1N2, R1N3, R1N4	RES, SMD, 0603, DNP-PLACE HOLDER, ROHS		
0	b) R162, R164, R165, R167, R168, R170, RCP	RES, SMD, 0603, 0Ω, 1/10W, TF, ROHS	VENKEL	CR0603-10W-000T
0	b) R200, R201, R204	RES, SMD, 0603, 10k, 1/10W, 1%, TF, ROHS	KOA	RK73H1JT1002F
0	b) R203, R206	RES, SMD, 0603, 1k, 1/10W, 1%, TF, ROHS	PANASONIC	ERJ-3EKF1001V
5	Bottom Four Corners and Center	BUMPONS, 0.44inWx0.20inH, DOMETOP, BLACK	3M	SJ-5003SPBL
0	c) C145, C146, C147, C148, C149, C150, C151	CAP, SMD, 0402, 0.1µF, 16V, 10%, X7R, ROHS	VENKEL	C0402X7R160-104KNE
0	c) R2N1, R2N3, R2N4, R3N1, R3N2, R3N4, R4N1	RES, SMD, 0603, DNP-PLACE HOLDER, ROHS		
0	c) RB1-RB4, R12V	RES, SMD, 0603, 0Ω, 1/10W, TF, ROHS	VENKEL	CR0603-10W-000T
4	C1, C13, C20, C101	CAP, SMD, 0603, 0.01µF, 16V, 10%, X7R, ROHS	VENKEL	C0603X7R160-103KNE

Application Note 1902

Bill of Materials (Continued)

QTY	REFERENCE DESIGNATOR	DESCRIPTION	MANUFACTURER	MANUFACTURER PART
0	C12, C14, C30, C36	CAP, SMD, 0603, DNP-PLACE HOLDER, ROHS		
6	C17, CB1-CB4, CCP	CAP, SMD, 0603, 0.22µF, 25V, 10%, X7R, ROHS	TDK	C1608X7R1E224K
3	C18, C51, C58	CAP, SMD, 0603, 0.056µF, 16V, 10%, X7R, ROHS	MURATA	GRM39X7R563K016AD
1	C19	CAP, SMD, 0603, 0.33µF, 16V, 10%, X7R, ROHS	VENKEL	C0603X7R160-334KNE
6	C1A, C3A, C4A, C5A, C7A, C8A	CAP-OSCON, RADIAL, 6.3X9, 560µF, 6.3V, 20%, 7mΩ, ROHS	PANASONIC/SANYO	6SEPC560MW
5	C2, C16, C23, C134, CC4	CAP, SMD, 0603, 1µF, 16V, 10%, X5R, ROHS	MURATA	GRM188R61C105KA12D
3	C200, C201, C202	CAP, SMD, 0603, 1000pF, 16V, 10%, X7R, ROHS	VENKEL	C0603X7R160102KNE
1	C21	CAP, SMD, 0603, 1800pF, 50V, 10%, X7R, ROHS	MURATA	GRM39X7R182K050AQ
4	C24, C25, C24A, C25A	CAP, RADIAL, 10x13, 56µF, 25V, 20%, ROHS	SANYO	25SEP56M
1	C26	CAP, SMD, 0603, 10pF, 50V, 5%, COG, ROHS	YAGEO	CC0603JRNPO9BN100
2	C3, C11	CAP, SMD, 0603, 1200pF, 50V, 10%, X7R, ROHS	PANASONIC	ECJ-1VB1H122K
4	C4, C7, C9, C10	CAP, SMD, 0603, 0.022µF, 25V, 10%, X7R, ROHS	MURATA	GRM188R71E223KA01J
1	C5	CAP, SMD, 0603, 100pF, 50V, 5%, COG, ROHS	PANASONIC	ECJ-1VC1H101J
1	C6	CAP, SMD, 0603, 22pF, 50V, 5%, COG, ROHS	VENKEL	C0603C0G500-220JNE
2	C73, C87	CAP, SMD, 0603, 0.1µF, 16V, 10%, X7R, ROHS	MURATA	GRM39X7R104K016AD
7	C79, C102, C103, C105, C107, C108, C109	CAP, SMD, 0805, 1µF, 16V, 10%, X7R, ROHS	KEMET	C0805C105K4RACTU
1	C8	CAP, SMD, 0603, 560pF, 25V, 20%, X7R, ROHS	VENKEL	C0603X7R250-561MNE
1	C81	CAP, SMD, 0603, 3900pF, 50V, 10%, X7R, ROHS	PANASONIC	ECJ-1VB1H392K
1	C82	CAP, SMD, 0603, 0.15µF, 25V, 10%, X7R, ROHS	VENKEL	C0603X7R250-154KNE
0	d) C154, C155	CAP, SMD, 0402, 0.1µF, 16V, 10%, X7R, ROHS	VENKEL	C0402X7R160-104KNE
0	d) R4N2, R4N3	RES, SMD, 0603, DNP-PLACE HOLDER, ROHS		
1	D1	LED, SMD, 3x2.5mm, 4P, RED/GREEN, 12/20MCD, 2V	LUMEX	SSL-LXA3025IGC-TR
1	HDR2	CONN-HEADER, 2x5, BRKAWY-2x36, 2.54mm, ROHS	BERG/FCI	67996-272HLF
1	J_USB	CONN-USB MINI-B RECEPTACLE, TH, 5CIRCUIT, R/A, ROHS	MOLEX	54819-0519

Application Note 1902

Bill of Materials (Continued)

QTY	REFERENCE DESIGNATOR	DESCRIPTION	MANUFACTURER	MANUFACTURER PART
3	J10, J15, J25	CONN-SCOPE PROBE TEST PT, COMPACT, PCB MNT, ROHS	TEKTRONIX	131-4353-00
4	J11, J12, J13, J14	HDWARE, MTG, CABLE TERMINAL, 6-14AWG, LUG&SCREW, ROHS	BERG/FCI	KPA8CTP
6	J16, J17, J18, J19, J23, JP16	CONN-HEADER, 1x2, RETENTIVE, 2.54mm, 0.230x0.120, ROHS	BERG/FCI	69190-202HLF
4	J1-J4	CONN-HEADER, 2x3, BRKAWY 2x36, 2.54mm, VERTICAL,ROHS	BERG/FCI	67996-272HLF
9	J1-J4-Two Center Pins, J16-J19, JP16	CONN-JUMPER, SHORTING, 2PIN, BLACK, GOLD, ROHS	SULLINS	SPC02SYAN
0	J20, J21, J22	DO NOT POPULATE OR PURCHASE		
1	J24	CONN-HEADER, 2x2, BRKAWY 2X36, 2.54mm, VERTICAL,ROHS	BERG/FCI	67996-272HLF
1	J5	CONN-GEN, BIND.POST, INSUL-RED, THMBNUT-GND	JOHNSON COMPONENTS	111-0702-001
1	J6	CONN-GEN, BIND.POST, INSUL-BLK, THMBNUT-GND	JOHNSON COMPONENTS	111-0703-001
1	J7	CONN-HEADER, DUAL, 4P, SHROUDED, NYLON, W/PEGS, ROHS	MOLEX	39-29-9042
1	J8	CONN-HEADER, 2x12, 4 SIDED, 4.2mm, VERTICAL, ROHS	MOLEX	39-29-9242
1	J9	CONN-SCOPE PROBE TEST PT, COMPACT, PCB MNT, ROHS	TEKTRONIX	131-5031-00
1	JCON	CONN-HEADER, 2x4, BRKAWY-2X36, 2.54mm, ROHS	BERG/FCI	67996-272HLF-2X4
1	JTAG1	CONN-HEADER, SHROUDED, SMD, 14P, 2mm PITCH, CENTER SLOT, ROHS	MOLEX	87832-1420
0	L1A-L4A (THCBR1290-221-R)	DO NOT POPULATE OR PURCHASE		
4	L1B-L4B	COIL-PWR INDUCTOR, TH 11x8, 0.3µH, 20%, 60A, ROHS	LIANZHEN ELECTRONICS CO., LTD.	INC0811-R30M-WM1W
1	Place assy in bag	BAG, STATIC, 10x12, ZIP LOC	INTERSIL	212403-015
2	Q1, Q14	TRANSISTOR,N-CHANNEL, 3LD, SOT-23, 60V, 115mA, ROHS	DIODES, INC.	2N7002-7-F
1	Q15	TRANSISTOR-MOS,N-CHANNEL, SMD, TO-252, 30V, 90A, ROHS	VISHAY	SUD50N03-06AP-E3
0	QH11, QH21, QH31, QH41 (BSC052N03LS)	DO NOT POPULATE OR PURCHASE		
4	QH12, QH22, QH32, QH42	TRANSIST-MOS,N-CHANNEL, 30V, 57A, SMD, 8P, PG-TDSON-8, ROHS	INFINEON TECHNOLOGY	BSC052N03LS
0	QL11, QL21, QL31, QL41 (BSC011N03LS)	DO NOT POPULATE OR PURCHASE		
4	QL12, QL22, QL32, QL42	TRANSIST-MOS, N-CHANNEL, 30V, 100A, SMD, 8P, PG-TDSON-8, ROHS	INFINEON TECHNOLOGY	BSC011N03LS
1	R1	RES, SMD, 0603, 88.7k, 1/10W, 1%, TF, ROHS	VENKEL	CR0603-10W-8872FT

Application Note 1902

Bill of Materials (Continued)

QTY	REFERENCE DESIGNATOR	DESCRIPTION	MANUFACTURER	MANUFACTURER PART
1	R10	RES, SMD, 0603, 301 Ω , 1/10W, 1%, TF, ROHS	KOA	RK73H1JT3010F
1	R102	RES, SMD, 0603, 49.9k, 1/10W, 1%, TF, ROHS	VENKEL	CR0603-10W-4992FT
2	R104, R105	RES, SMD, 0603, 11 Ω , 1/10W, 1%, TF, ROHS	VENKEL	CR0603-10W-11R0FT
1	R106	RES, SMD, 2512, 0.22 Ω , 1W, 1%, TF, ROHS	DALE	WSL-2512-R220F
1	R107	RES, SMD, 2512, 0.1 Ω , 1W, 1%, TF, ROHS	DALE	WSL-2512-R100F
1	R11	RES, SMD, 0603, 3.16k, 1/10W, 1%, TF, ROHS	PANASONIC	ERJ-3EKF3161V
1	R113	RES, SMD, 0603, 49.9 Ω , 1/10W, 1%, TF, ROHS	VENKEL	CR0603-10W-49R9FT
4	R12, R13, R15, R103	RES, SMD, 0603, 499 Ω , 1/10W, 1%, TF, ROHS	VENKEL	CR0603-10W-4990FT
1	R120	RES, SMD, 0603, 1.10k, 1/10W, 1%, TF, ROHS	PANASONIC	ERJ-3EKF1101V
1	R137	RES, SMD, 0603, 22.6 Ω , 1/10W, 1%, TF, ROHS	VISHAY/DALE	CRCW060322R6FKEA
1	R155	RES, SMD, 0603, 15k, 1/10W, 1%, TF, ROHS	PANASONIC	ERJ-3EKF1502V
1	R16	RES, SMD, 0603, 102k, 1/10W, 1%, TF, ROHS	PANASONIC	ERJ-3EKF1023V
7	R17, R18, R35, R88, R90, R92, R94	RES, SMD, 0603, 10 Ω , 1/10W, 1%, TF, ROHS	KOA	RK73H1JT10R0F
0	R175, R176	RES, SMD, 0402, DNP, DNP, DNP, TF, ROHS		
2	R19, R21	RES, SMD, 0603, 10k, 1/10W, 0.1%, MF, ROHS	PANASONIC	ERA-3YEB103V
1	R2	RES, SMD, 0603, 9.53k, 1/10W, 1%, TF, ROHS	VENKEL	CR0603-10W-9531FT
1	R202	RES, SMD, 0603, 5.62k, 1/10W, 1%, TF, ROHS	PANASONIC	ERJ-3EKF5621V
1	R205	RES, SMD, 0603, 1.4k, 1/10W, 1%, TF, ROHS	YAGEO	RC0603FR-071K4L
2	R23, R25	RES, SMD, 0603, 1k, 1/10W, 0.1%, MF, ROHS	PANASONIC	ERA-3AEB102V
2	R24, R31	RES, SMD, 0603, 5.1MEG, 1/10W, 1%, TF, ROHS	VISHAY/DALE	CRCW06035M10FKEA
1	R3	RES, SMD, 0603, 64.9k, 1/10W, 1%, TF, ROHS	VENKEL	CR0603-10W-6492FT
1	R30	RES, SMD, 0603, 383 Ω , 1/10W, 1%, TF, ROHS	YAGEO	RC0603FR-07383RL
1	R37	RES, SMD, 0603, 1 Ω , 1/10W, 1%, TF, ROHS	PANASONIC	ERJ-3RQF1R0V
1	R38	RESISTOR, SMD, 0603, 11k, 1/10W, 1%, TF, ROHS	PANASONIC	ERJ-3EKF1102V

Application Note 1902

Bill of Materials (Continued)

QTY	REFERENCE DESIGNATOR	DESCRIPTION	MANUFACTURER	MANUFACTURER PART
1	R41	RES, SMD, 0603, 2.61k, 1/10W, 1%, TF, ROHS	VENKEL	CR0603-10W-2611FT
1	R42	THERMISTOR, SMD, 0603, 10k, 1/10W, 5%, B-VALUE = 4201-4300K	PANASONIC	ERT-J1VR103J-T
1	R46	THERMISTOR-NTC, SMD, 0603, 470k, 1/10W, 5%, B-VALUE = 4500, ROHS	MURATA	NCP18WM474J03RB-T
1	R49	RES, SMD, 0603, 3.83k, 1/10W, 1%, TF, ROHS	VENKEL	CR0603-10W-3831FT
2	R5, R14	RES, SMD, 0603, 56.2Ω, 1/10W, 1%, TF, ROHS	YAGEO	RC0603FR-0756R2L
4	R63, R65, R67, R69	RES, SMD, 0603, 3.65k, 1/10W, 1%, TF, ROHS	YAGEO	RC0603FR-073K65L
1	R7	RES, SMD, 0603, 140k, 1/10W, 1%, TF, ROHS	VENKEL	CR0603-10W-1403FT
4	R71, R72, R73, R74	RES, SMD, 0603, 100k, 1/10W, 1%, TF, ROHS	VENKEL	CR0603-10W-1003FT
4	R8, R109, R143, R144	RES, SMD, 0603, 100Ω, 1/10W, 1%, TF, ROHS	VENKEL	CR0603-10W-1000FT
1	R80	RES, SMD, 0603, 27.4k, 1/10W, 1%, TF, ROHS	PANASONIC	ERJ-3EKF2742V
2	S2,S3	SWITCH-TOGGLE, SMD, 6PIN, SPDT, 3POS, ON-OFF-ON, ROHS	ITT INDUSTRIES/C&K DIVISION	GT13MSCBE
1	S4	DIODE-DUAL SWITCHING, SMD, SOT23, 75V, 0.3A, 350mW, ROHS	DIODES INC.	BAV99-7-F
38	TP1,TP4-TP26, TP28, TP32-TP42, TP44, TPW4	CONN-MINI TEST POINT, VERTICAL, WHITE, ROHS	KEYSTONE	5002
6	TP2, TP3, TP27, TP29-TP31	CONN-TURRET, TERMINAL POST, TH, ROHS	KEYSTONE	1514-2
1	U1	IC-MULTI-PHASE PWM CONTROLLER, 40P, TQFN, ROHS	INTERSIL	ISL95820CRTZ
1	U10	OSC-CLOCK, CRYSTAL, SMD, 5x7, 3.3V, 100MHz, 25ppm, ROHS	CONNOR-WINFIELD	CWX813-100.0M
1	U11	IC-FLASH, 32k, MICROCONTROLLER, 48P, TQFP, 25MIPS, ROHS	SILICON LABORATORIES	C8051F348-GQ
1	U12	IC-PLATFORM FLASH PROM, 1Mb, 20P, TSSOP, ROHS	XILINX	XCF01SVOG20C
1	U13	IC-STD.FPGA SPARTAN-3, SMD, 100P, VTQFP, ROHS	XILINX	XC3S50-4VQG100C
0	U14 (FXLP34P5X)	DO NOT POPULATE OR PURCHASE		
1	U2 (BACKPLATE)	CONN-CPU BACK PLATE W/SCREWS, 115XP,LGA, ROHS	FOXCONN	PT44P18-6401
1	U2 (ILM)	CONN-CPU ILM, 115XP, LGA, ROHS	FOXCONN	PT44L61-6401
1	U2 (SOCKET)	CONN-CPU SOCKET H3, SMD, 1150P, LGA, ROHS	FOXCONN	PE115027-4041-01F
1	U2 ASSY	SCREW-SHOULDER, F.U.W. LGA1156 SKT, STAINLESS, ROHS	TYCO ELECTRONICS	2013884-1

Application Note 1902

Bill of Materials (Continued)

QTY	REFERENCE DESIGNATOR	DESCRIPTION	MANUFACTURER	MANUFACTURER PART
2	U2 ASSY	SCREW-ILM, F.U.W. LGA1156 ILM SKT, STAINLESS, ROHS	TYCO ELECTRONICS	2040979-1
1	U4	IC-ADJ.SHUNT REGULATOR, SMD, SOT-23, 1.2V, ROHS	NATIONAL SEMICONDUCTOR	LMV431AIMF/NOPB
1	U5	IC-HI FREQ BRIDGE DRIVER, 8P, SOIC, 100V, ROHS	INTERSIL	HIP2100IBZ
3	U6, U8, U9	IC-ADJ.V,1A LDO REGULATOR, 10P, DFN, 3X3, ROHS	INTERSIL	ISL80101IRAJZ
1	UD4	IC-DUAL MOSFET DRIVER, 8P, DFN, 2X2, ROHS	INTERSIL	ISL6625ACRZ
1		PWB-PCB, ISL95820EVAL1Z, REVD, ROHS	TBD	ISL95820EVAL1ZREVDPCB

ISL95820EVAL1Z Rev D Schematics

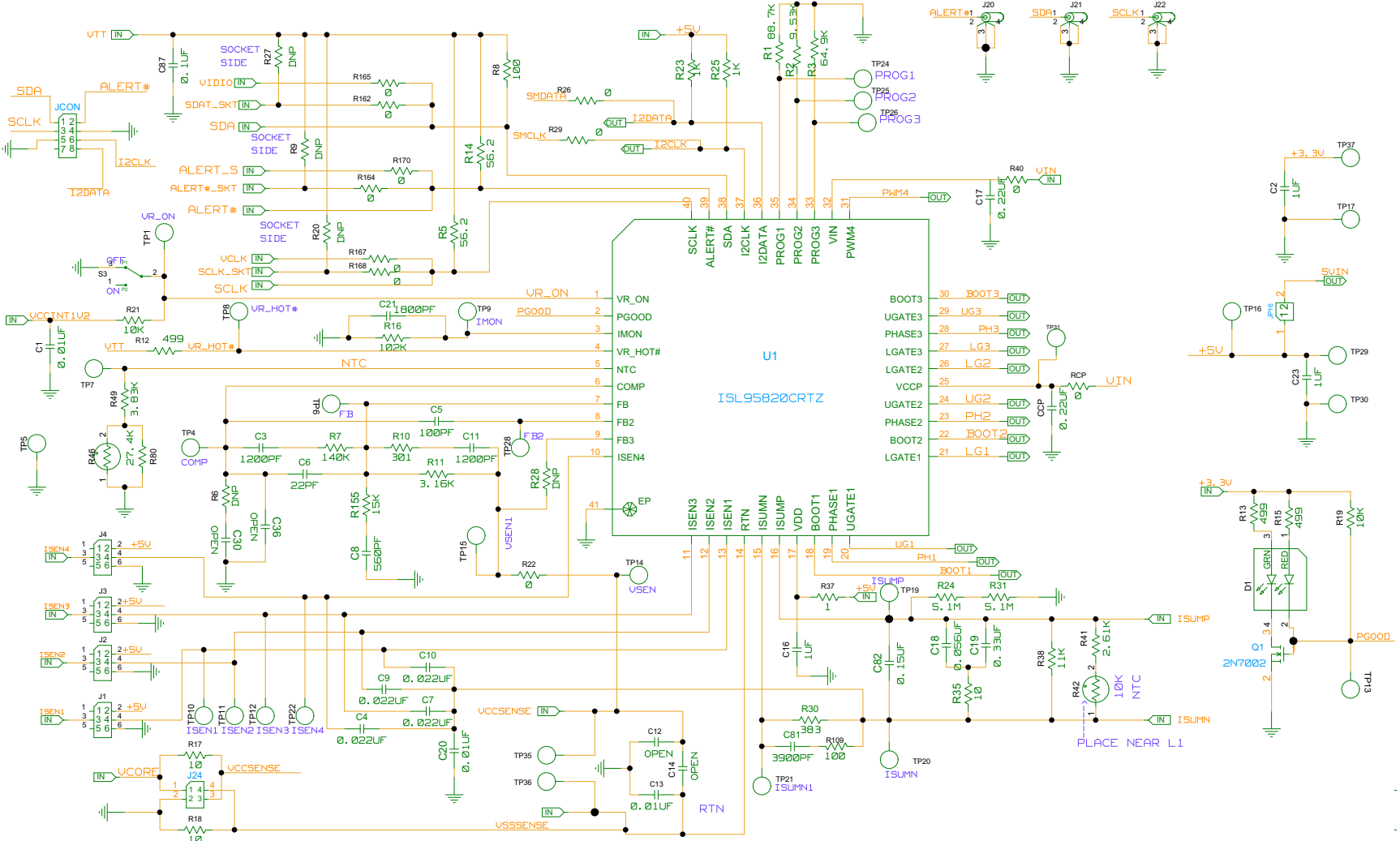

FIGURE 4. ISL95820EVAL1Z REV D SCHEMATIC, CONTROLLER, 1 OF 9

ISL95820EVAL1Z Rev D Schematics (Continued)

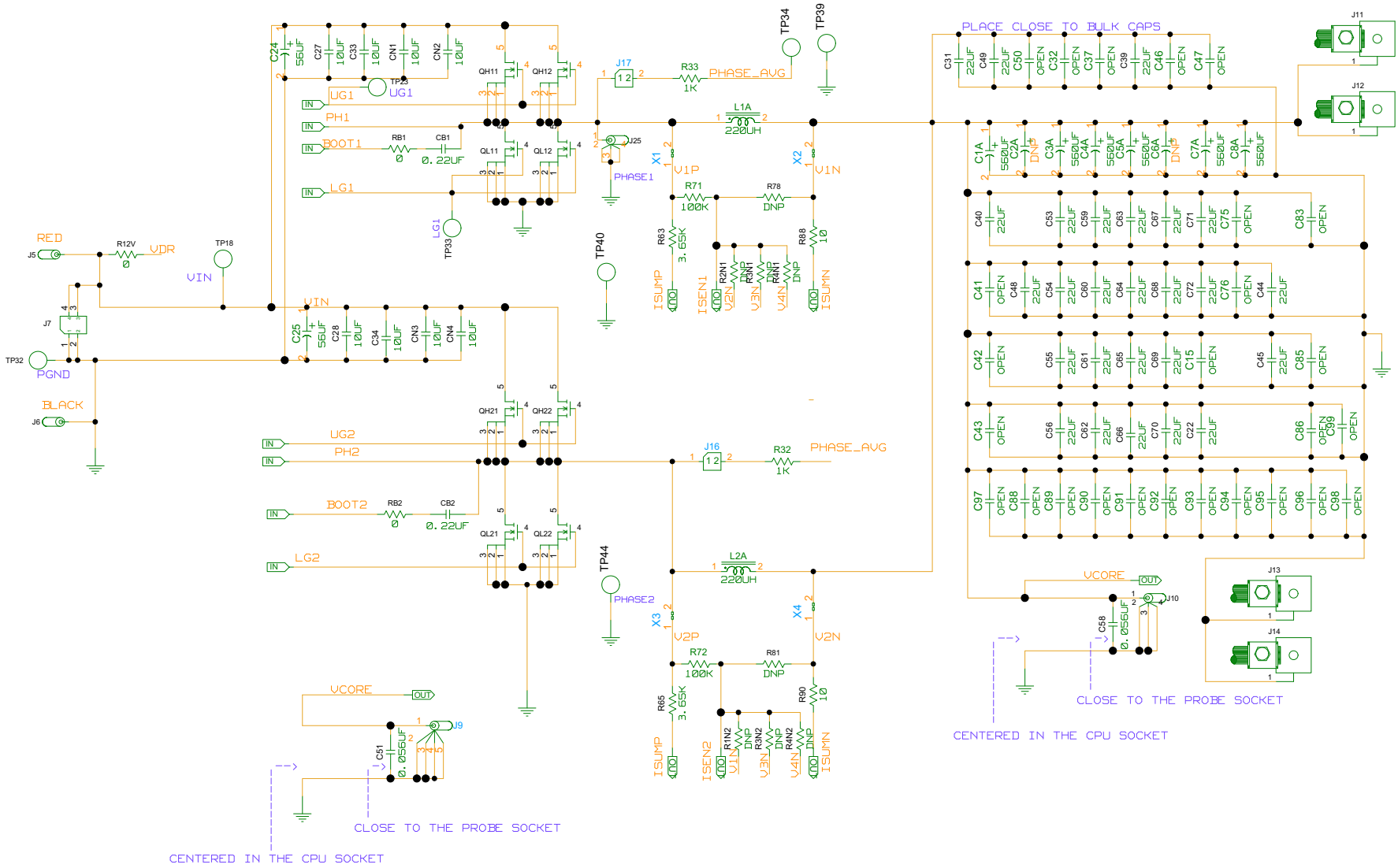

FIGURE 5. ISL95820EVAL1Z REV D SCHEMATIC, POWER STAGE PHASE 1/2, 2 OF 9

ISL95820EVAL1Z Rev D Schematics (Continued)

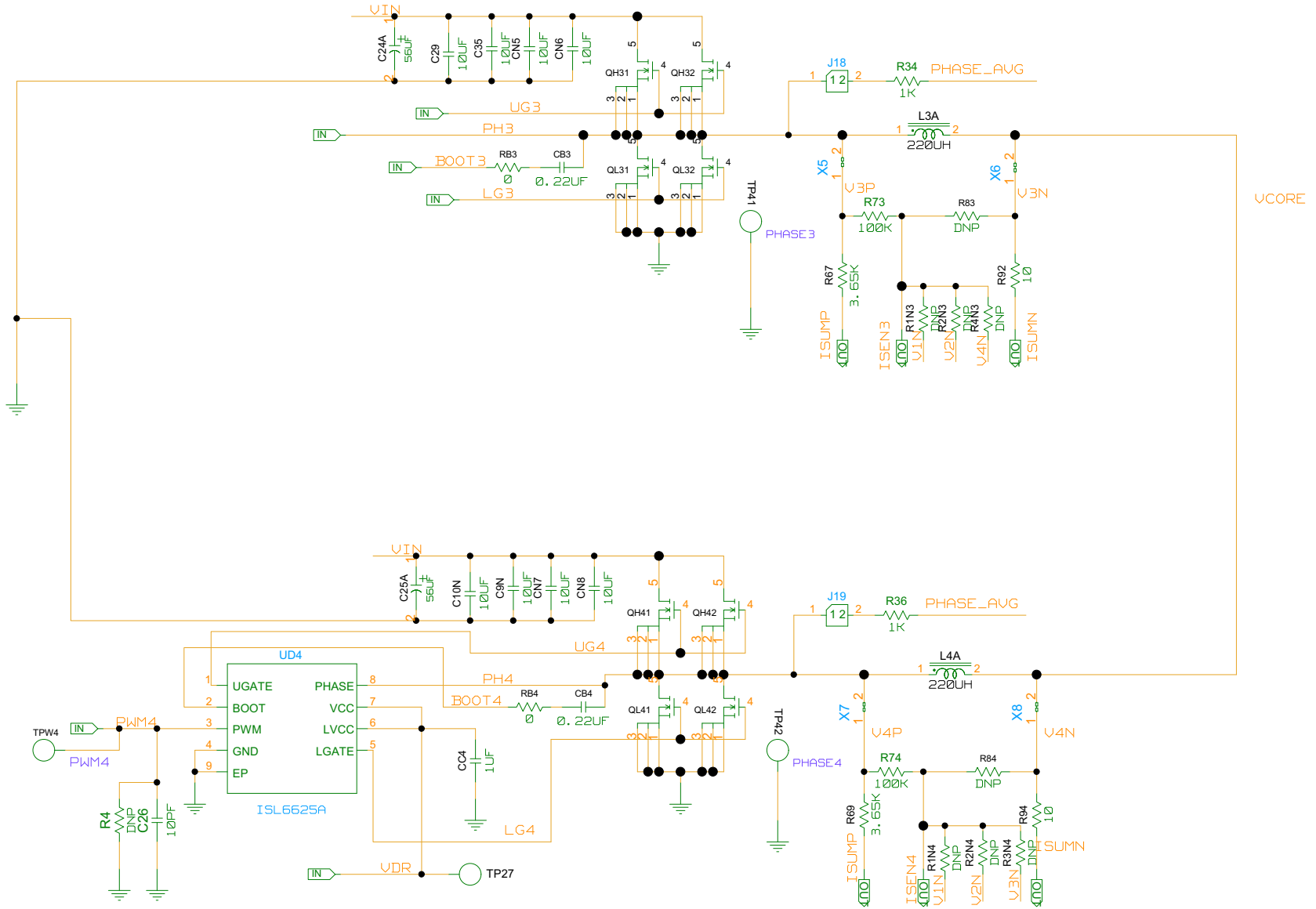

FIGURE 6. ISL95820EVAL1Z REV D SCHEMATIC, POWER STAGE PHASE 3/4, 3 OF 9

ISL95820EVAL1Z Rev D Schematics (Continued)

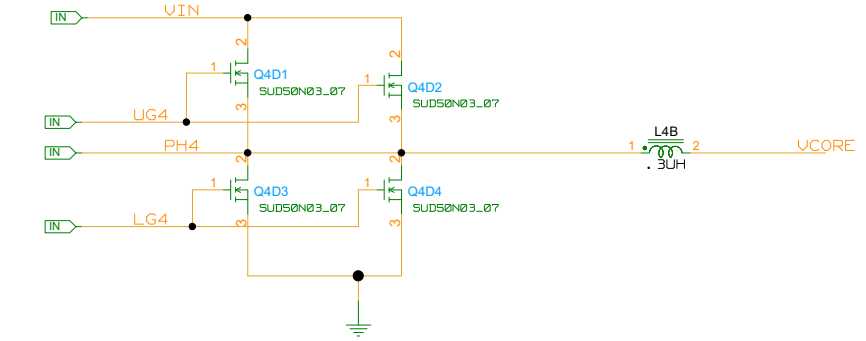
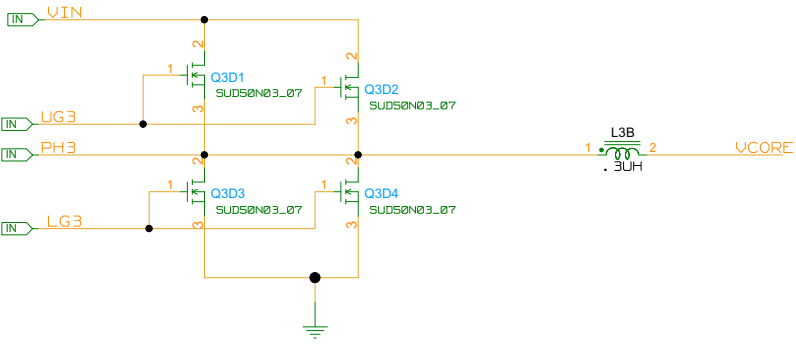
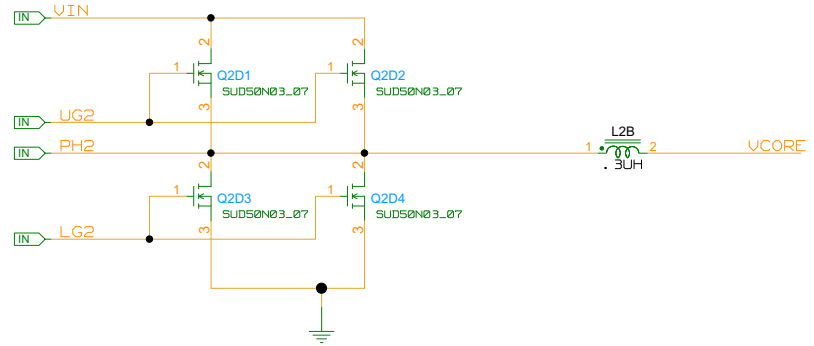
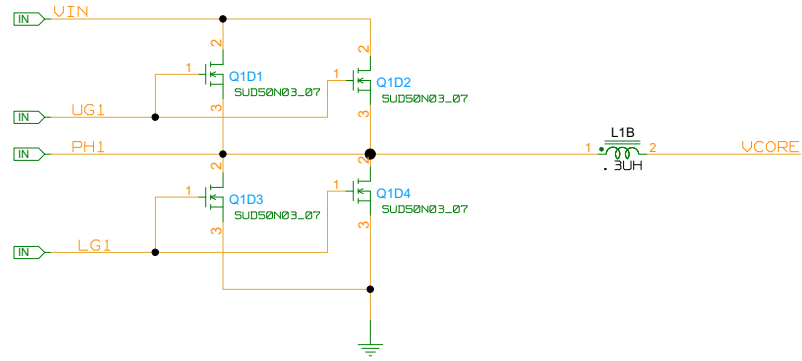

FIGURE 7. ISL95820EVAL1Z REV D SCHEMATIC, POWER STAGE DUAL LAYOUT, 40F 9

ISL95820EVAL1Z Rev D Schematics (Continued)

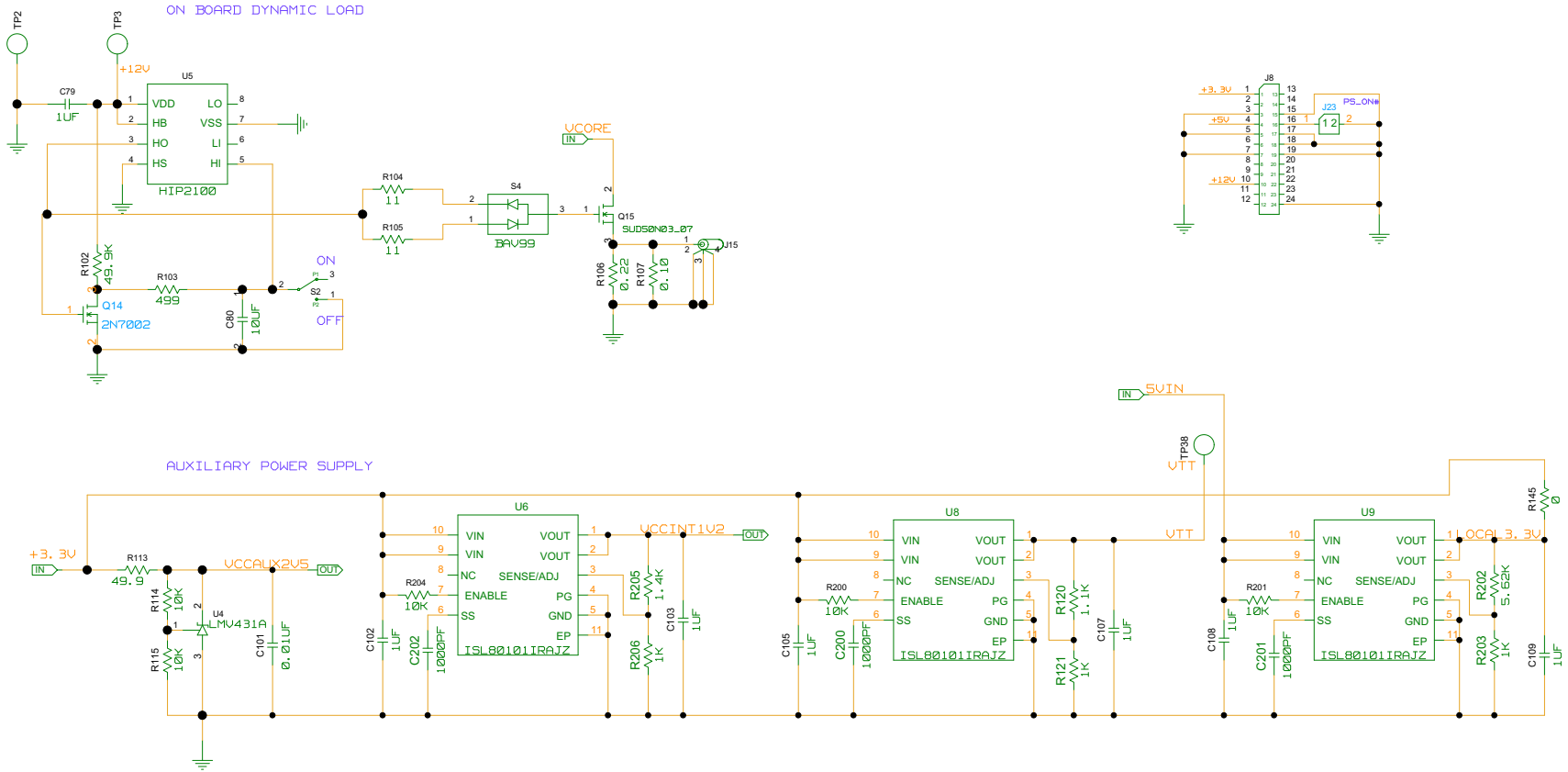

FIGURE 8. ISL95820EVAL1Z REV D SCHEMATIC, DYNAMIC LOAD EMULATOR AND AUX POWER, 5 OF 9

ISL95820EVAL1Z Rev D Schematics (Continued)

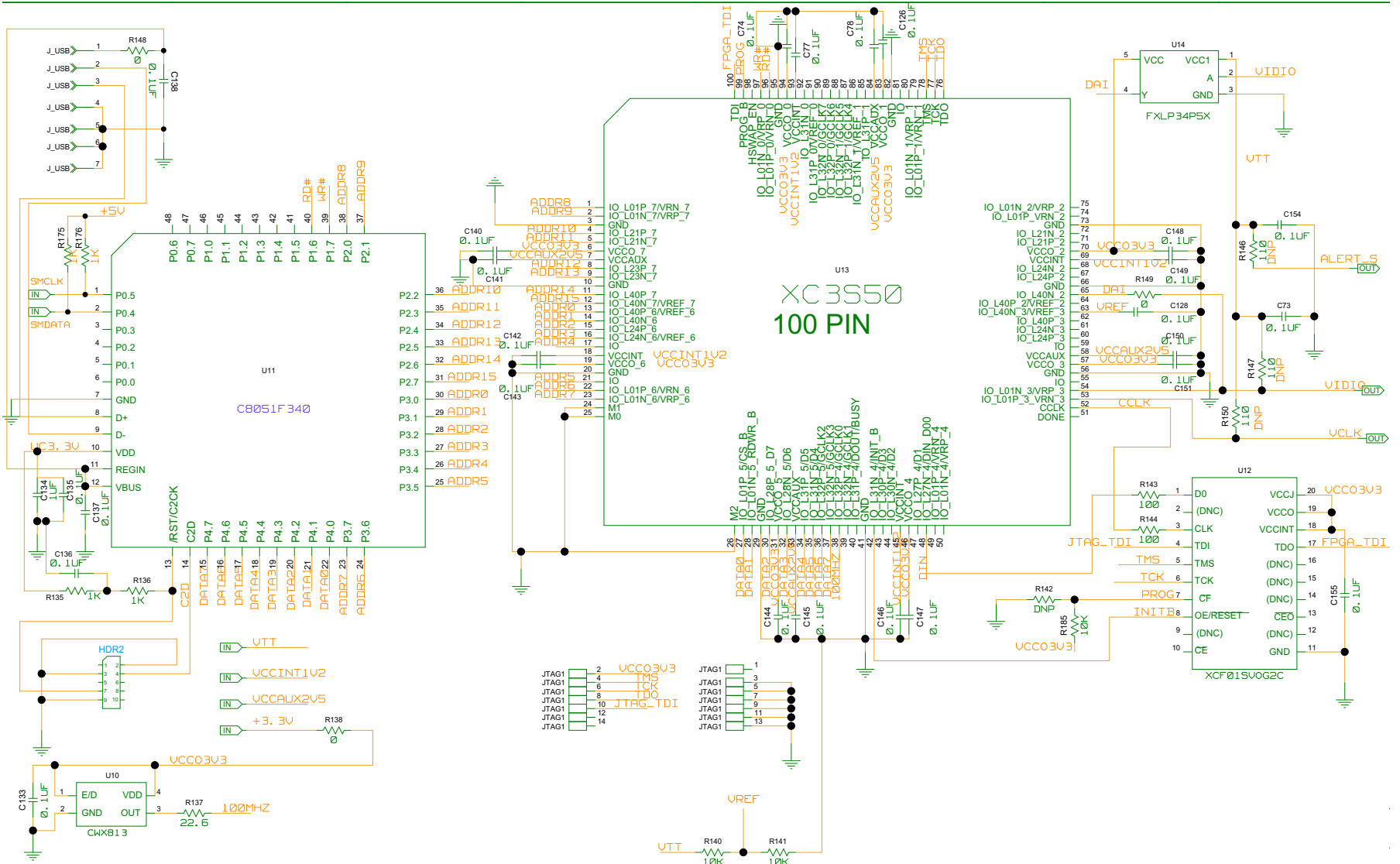

FIGURE 9. ISL95820EVAL1Z REV D SCHEMATIC, 5VID EMULATOR, 6 OF 9

ISL95820EVAL1Z Rev D Schematics (Continued)

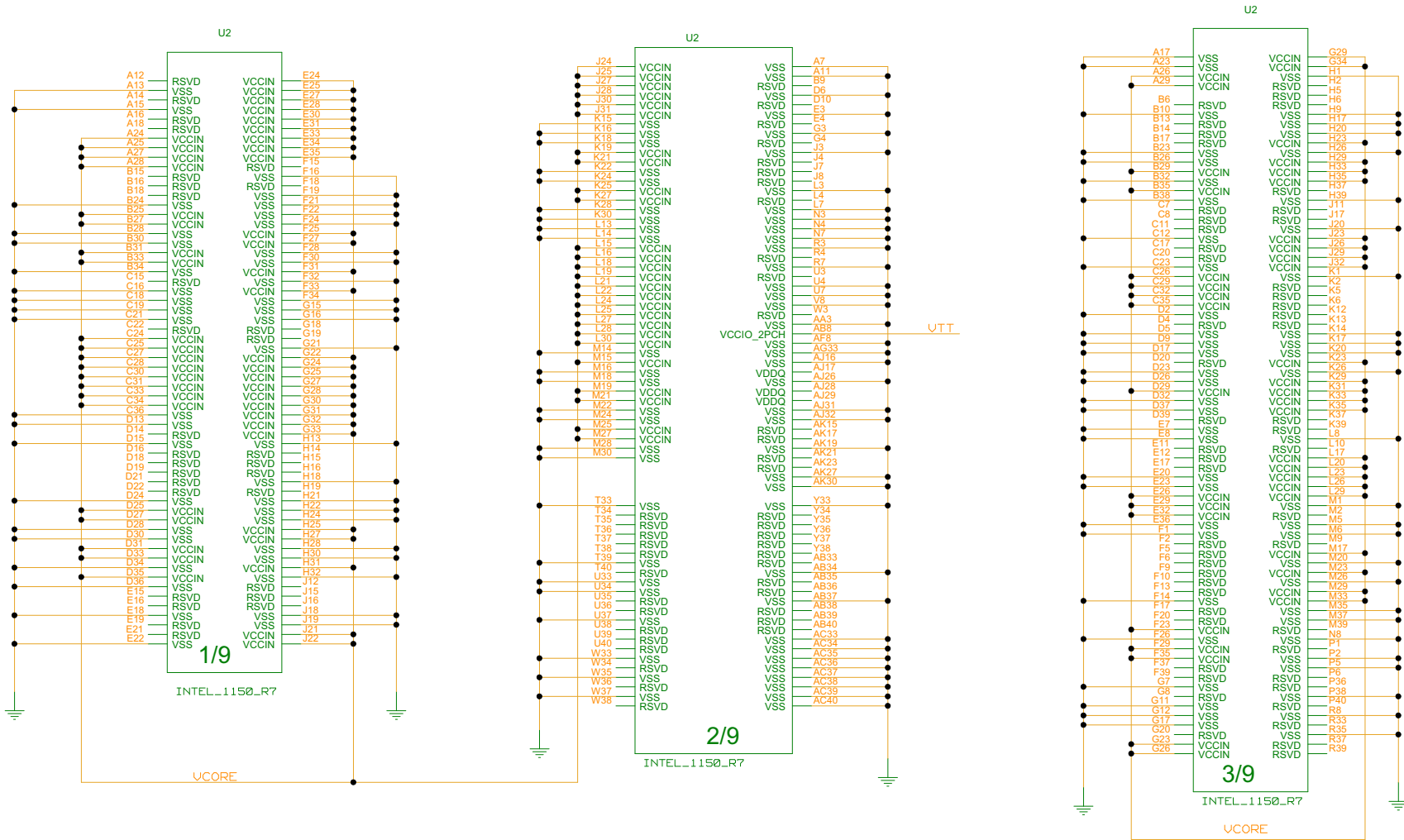

FIGURE 10. ISL95820EVAL1Z REV D SCHEMATIC, CPU SOCKET PART 1, 7 OF 9

ISL95820EVAL1Z Rev D Schematics (Continued)

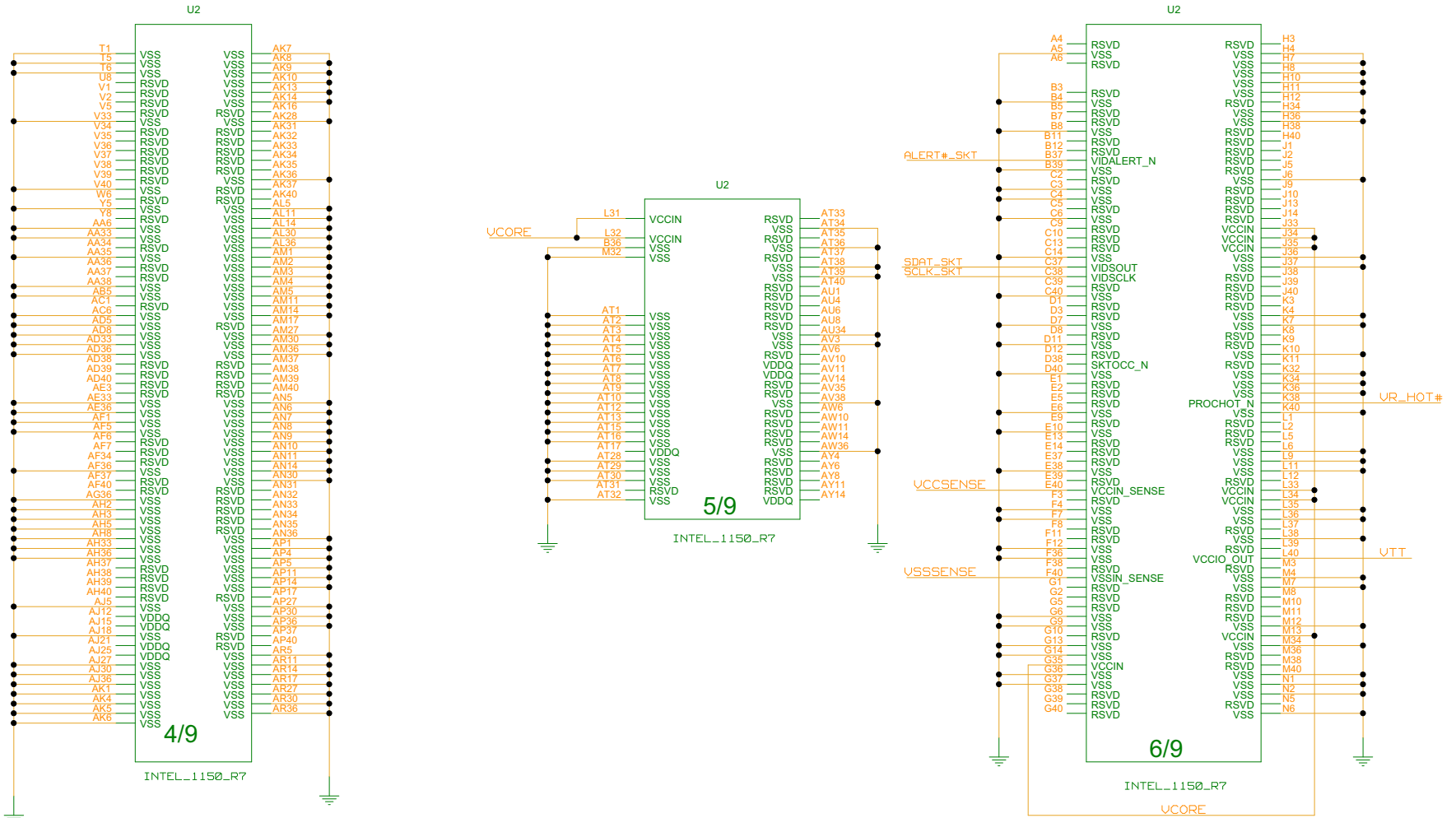

FIGURE 11. ISL95820EVAL1Z REV D SCHEMATIC, CPU SOCKET PART 2, 8 OF 9

ISL95820EVAL1Z Rev D Schematics (Continued)

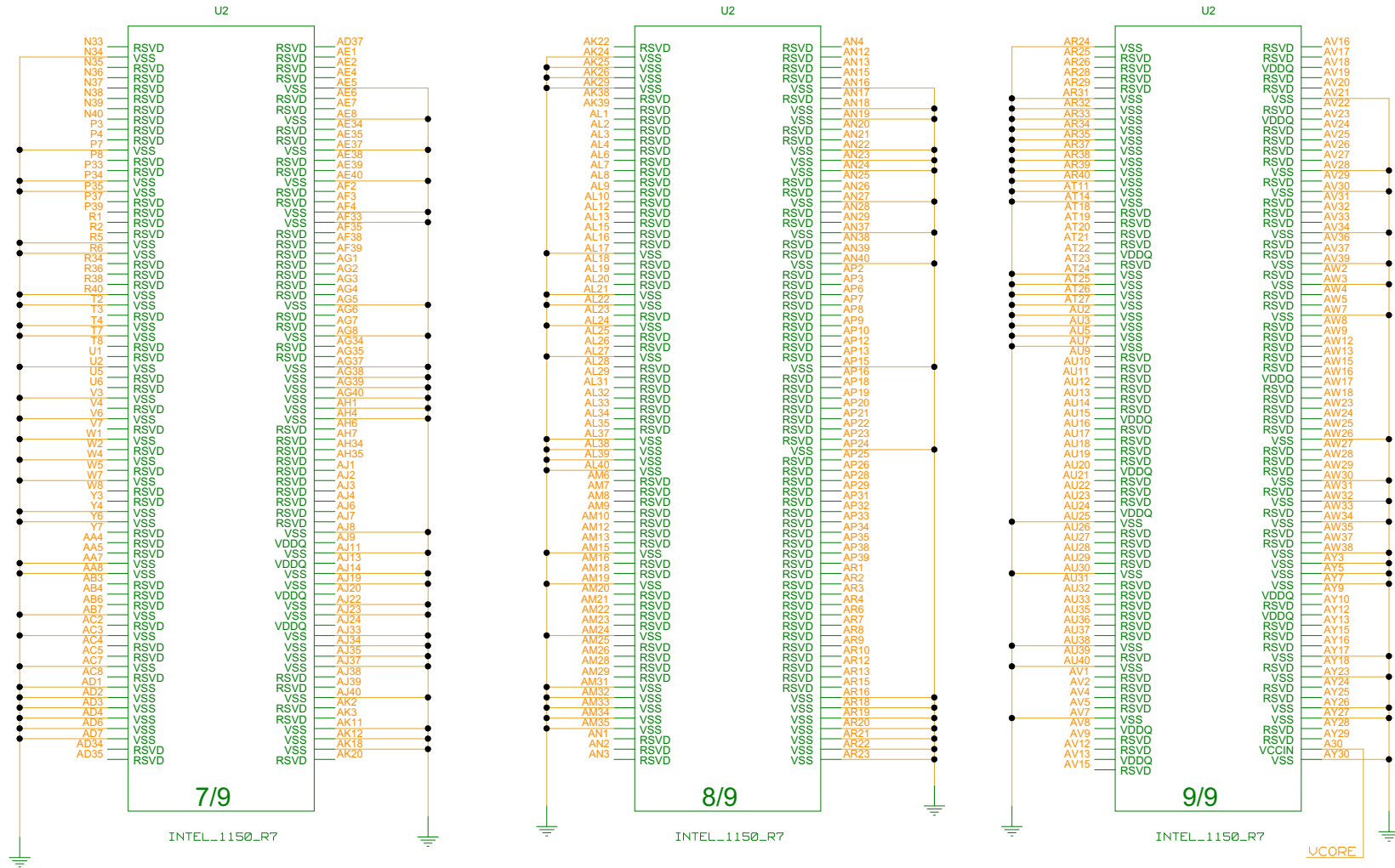

FIGURE 12. ISL95820EVAL1Z REV D SCHEMATIC, CPU SOCKET PART 3, 9 OF 9

ISL95820EVAL1Z Rev D Evaluation Board Layout

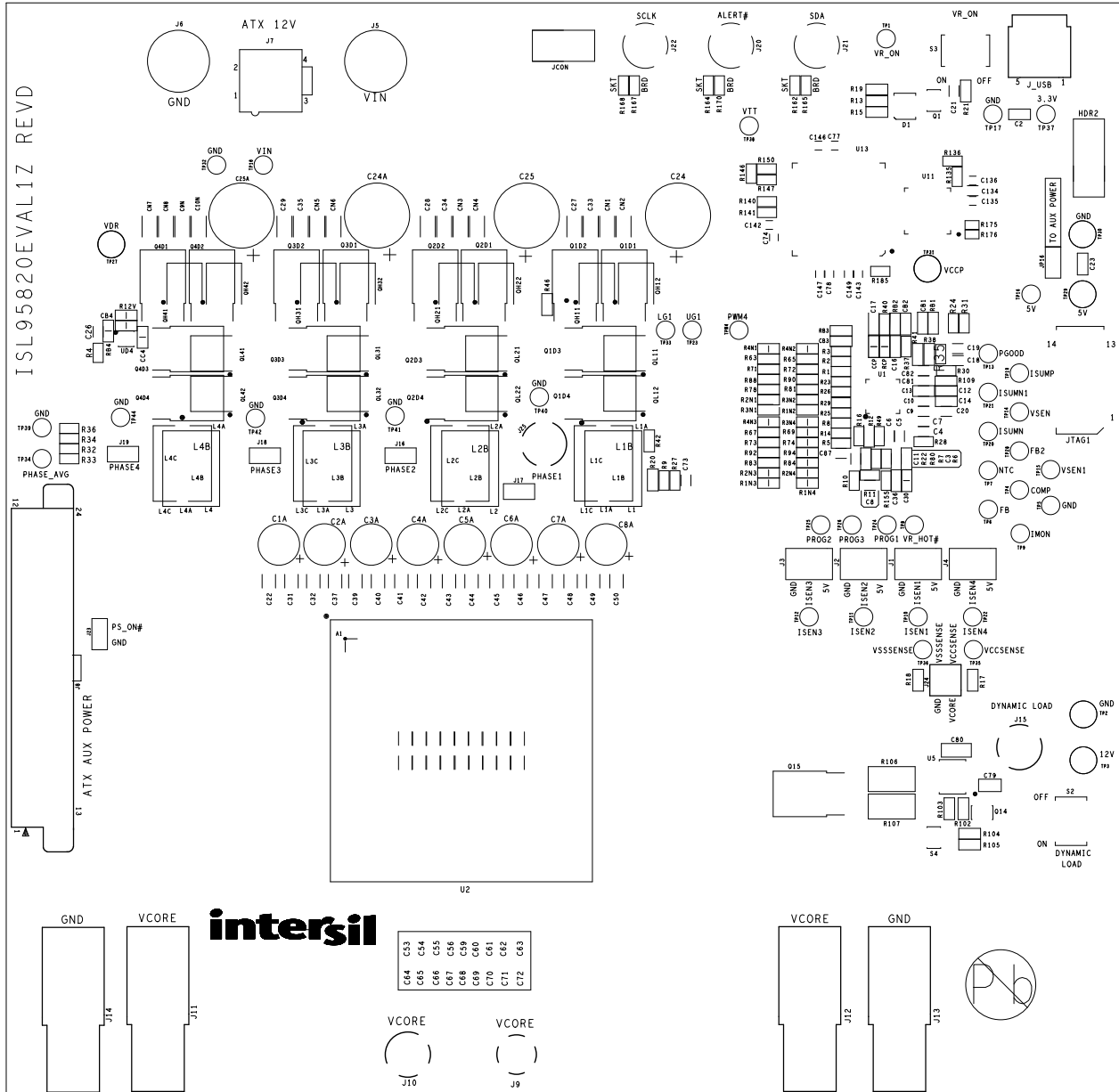

FIGURE 13. TOP SILKSCREEN

ISL95820EVAL1Z Rev D Evaluation Board Layout (Continued)

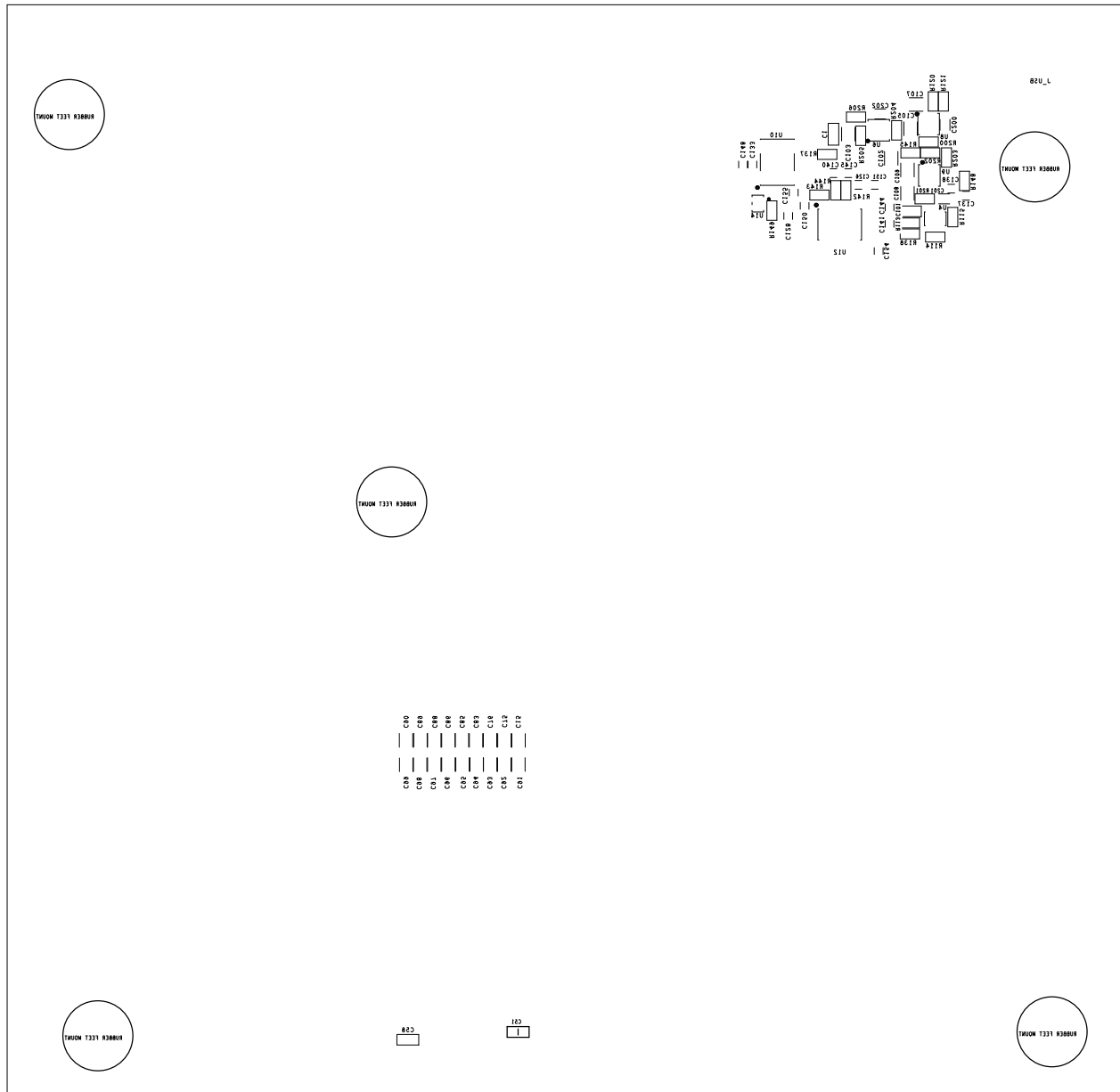

FIGURE 14. BOTTOM SILKSCREEN

ISL95820EVAL1Z Rev D Evaluation Board Layout (Continued)

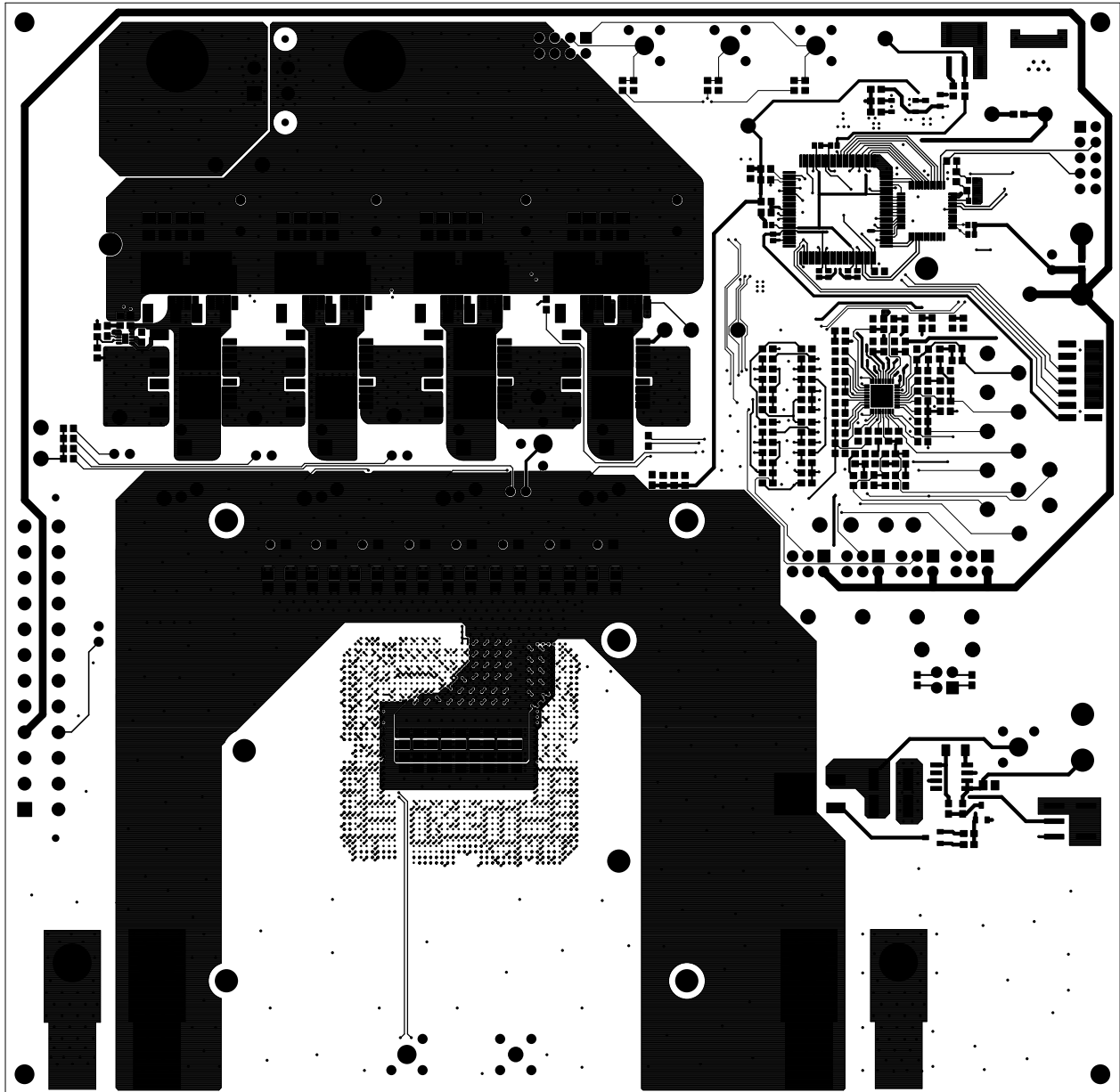

FIGURE 15. LAYER 1

ISL95820EVAL1Z Rev D Evaluation Board Layout (Continued)

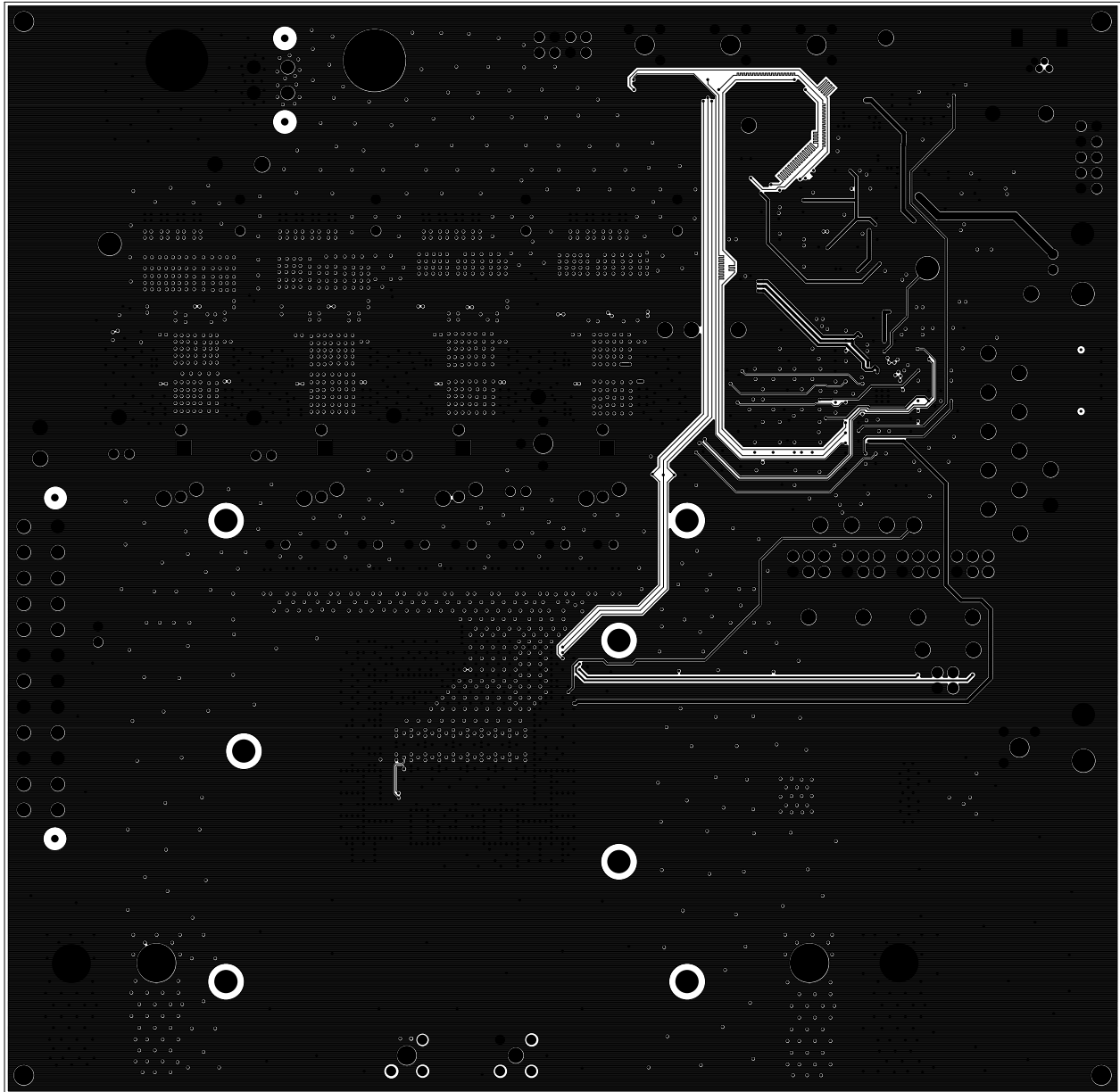

FIGURE 16. LAYER 2

ISL95820EVAL1Z Rev D Evaluation Board Layout (Continued)

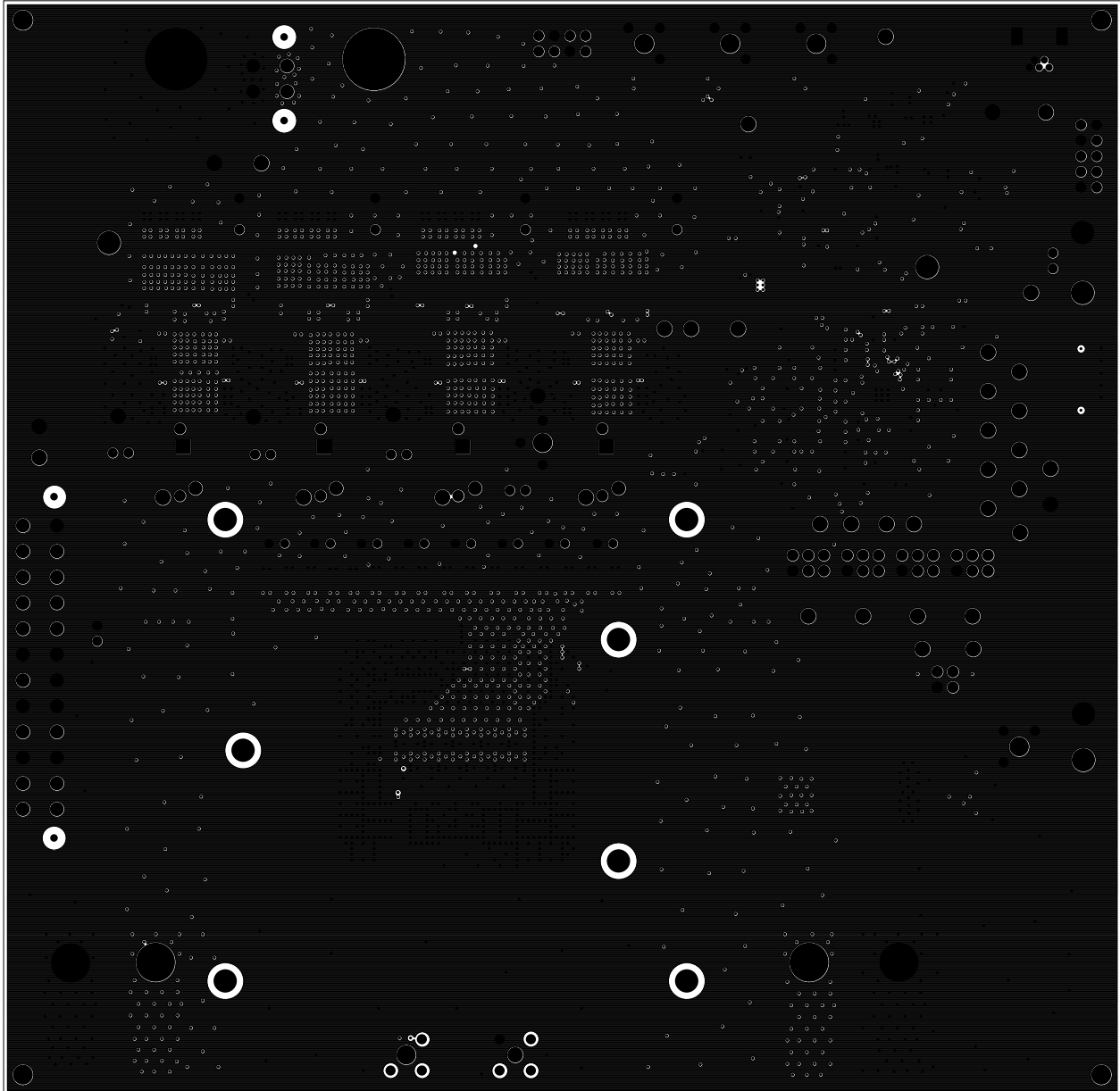

FIGURE 17. LAYER 3

ISL95820EVAL1Z Rev D Evaluation Board Layout (Continued)

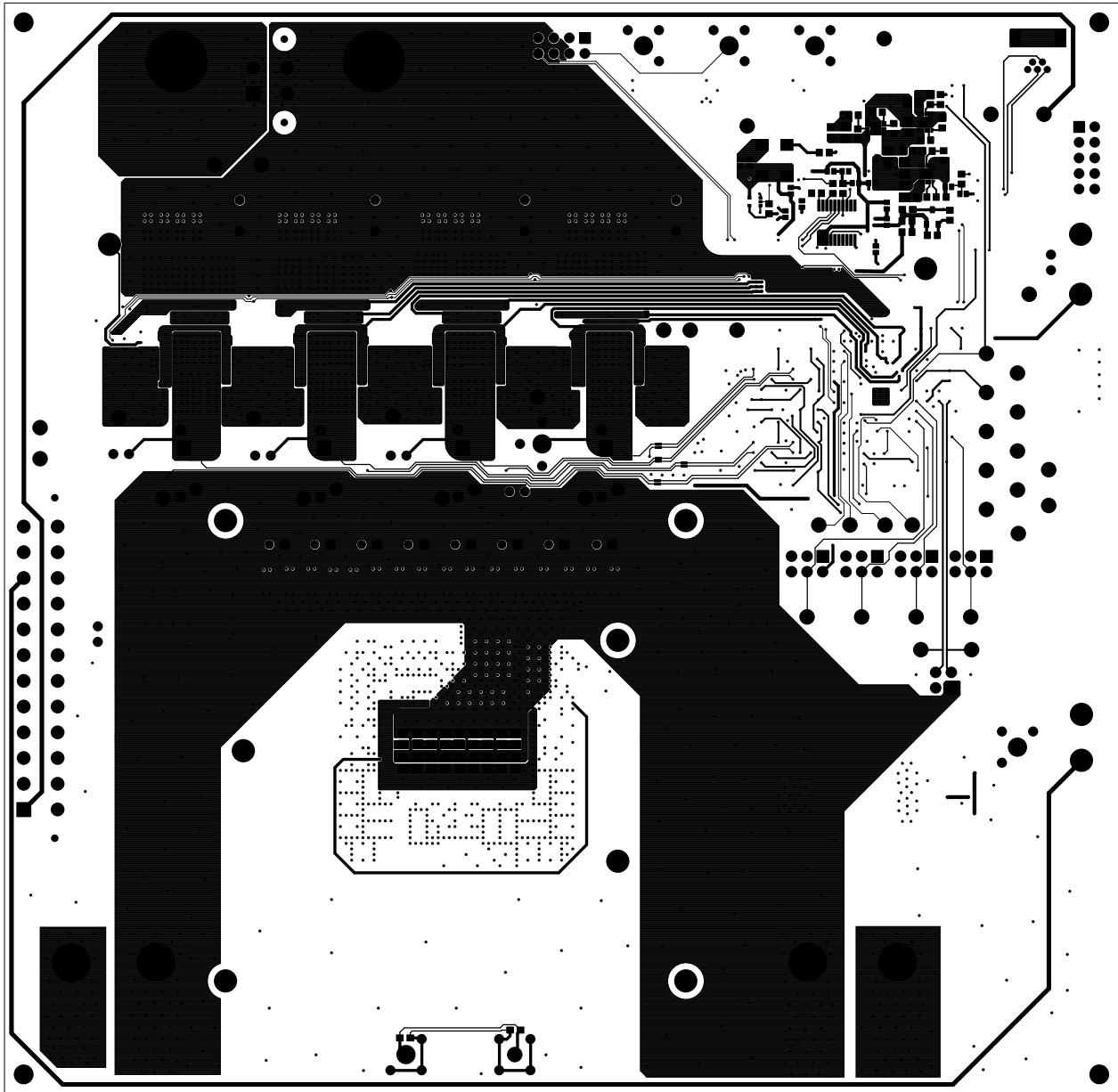

FIGURE 18. LAYER 4

Intersil Corporation reserves the right to make changes in circuit design, software and/or specifications at any time without notice. Accordingly, the reader is cautioned to verify that the Application Note or Technical Brief is current before proceeding.

For information regarding Intersil Corporation and its products, see www.intersil.com